

KAWAI

K

U P R I G H T P I A N O S



NEXT GENERATION PIANO

Kawai Upright Pianos

For over forty years, Kawai has been the architect of the modern piano, boldly pioneering the use of state-of-the-art materials and ideas to advance the piano art form.

While our nine decades of experience and tradition have enabled the creation of remarkable touch and tone for today, it is our celebrated technology that powerfully preserves and sustains that outstanding touch and tone for tomorrow. This innovative spirit is the essence of Kawai—and the principal reason why we remain a generation ahead in providing exceptional performance that endures.



PLEASANT SOUNDS

SOUND

Tradition and technology are indispensable elements of piano tone. Tradition lays the foundation for our distinctive tonal character. Technology empowers it with life, breadth, and depth that lasts from generation to generation.



Mahogany wood core &

T-stapled, double felted hammers

Mahogany hammer mouldings are lightweight and extremely responsive. Found on only the finest pianos, mahogany is used for the hammer mouldings on the entire line of K Series Professional Upright Pianos. All K Series hammers are T-Stapled to preserve hammer shape and fitted with an added interior layer of underfelt to support the creation of exceptional tone.



Tuning Pins

K Series tuning pins are made from the finest steel, machine-threaded for maximum bi-directional torque and nickel plated to enhance beauty and provide long-term protection.

Energy-Reflecting Contour Bars

Contour Bars reshape the speaking area of the soundboard to resemble the contour of a grand piano soundboard while reflecting sound energy back into the center for increased tonal power and sustain.

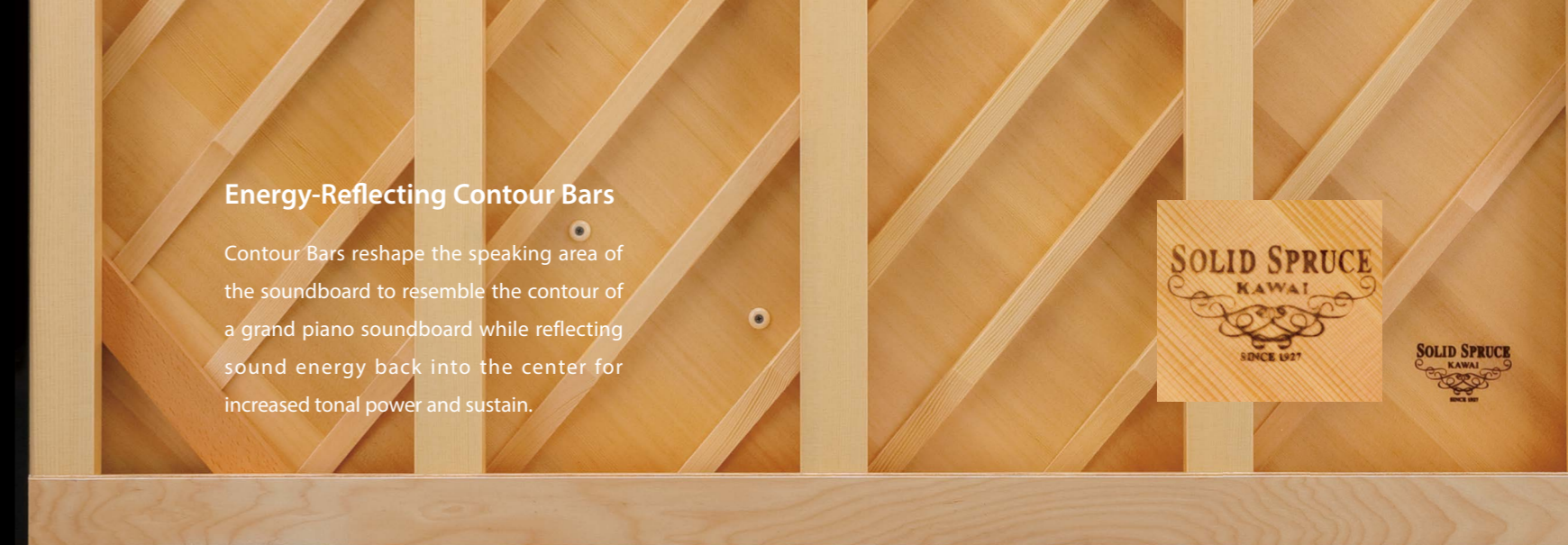

Strong, Balanced Back Assembly

K Series pianos are designed with tremendous strength to ensure stability of tone and touch over time. On all K Series models, the soundboard is supported by exceptionally strong multi-laminated back posts and our proprietary "matched strength" iron plate. This philosophy ensures a sturdy, well-balanced back assembly that supports string tension and provides a solid foundation for outstanding tone.



Tapered Soundboard made of Solid Spruce

The soundboard is the heart of a piano. Its purpose is to transform the vibrations of the piano's strings into a rich, resonating tone. Kawai uses only straightgrained, quarter-sawn solid spruce for K Series soundboards. Each soundboard is strategically tapered to maximize its tone producing capability. Only those that meet or exceed our demanding quality standards are selected for use in our professional upright pianos.

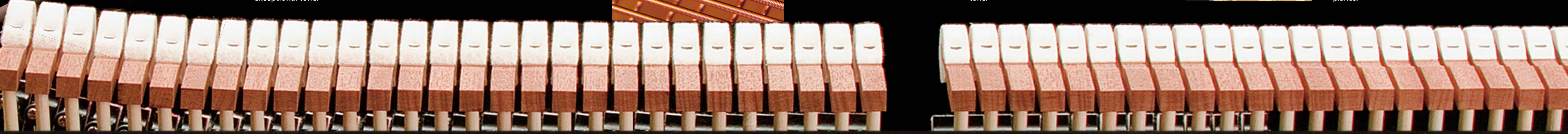

ATTRACTIVE CABINET STYLING

BEAUTY

The K Series pianos feature sleek lines and delicate accents that convey a striking, stately presence. By combining elegant form with rich, vibrant textures of tone, they will surely enhance the cultural ambiance of any room.



Cast Brass Pedals

Our proprietary casting process binds molten brass to a sturdy steel core resulting in strong, beautiful pedals that will not wear through over time.

Wide Music Rack

Conveniently built into the fallboard, the music rack on K-600, K-500, K-300 and K-200 extends nearly 1,000mm to accommodate multiple music books or sheet music that extends laterally.

Brass Front Casters

Front casters made of solid brass are as sturdy as they are attractive. Double casters are used for the larger K Series models



Soft-Fall Fallboard Closing System

The ultra-slow "Soft-Fall" closing system protects hands and the piano's finish from the harm that a jarring close might cause.



The Eternal Beauty of an Upright Piano

Modern design shines in space. A design that was born from the fusion of new ideas and modern technology, and assembled with the highest accuracy. With its square form and dynamic lines, the K series has a simple yet certain personality, in which we meet beauty for the first time.





K-500



K-300



K-200

K-500 K-300 K-200

K-500, K-300 and K-200 offer the dependability and character needed to please any performing pianist from the novice to the seasoned professional.

K-500

Height 130 cm Width 150 cm Depth 62 cm Weight 238 kg

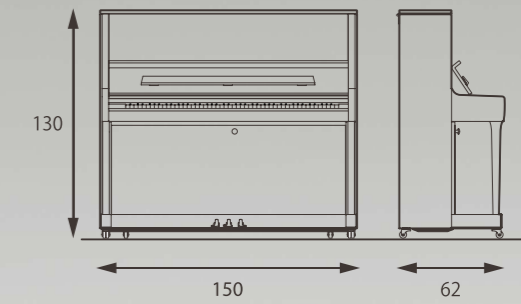

- Exclusive Millennium III Upright Action with ABS-Carbon Composites
- Duplex Scale (Fore)
The duplex scale enhances harmonics in the treble range, adding brilliance and richness to the piano's tone.
- NEOTEX™ Key Surfaces
- Double Felted, Mahogany Core Hammers

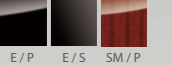

K-300

Height 122 cm Width 149 cm Depth 61 cm Weight 227 kg

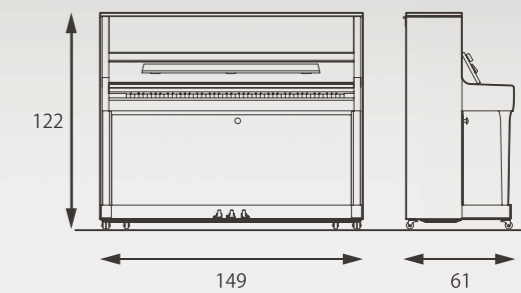

- Exclusive Millennium III Upright Action with ABS-Carbon Composites
- Double Felted, Mahogany Core Hammers

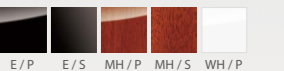

K-200

Height 114 cm Width 149 cm Depth 57 cm Weight 208 kg

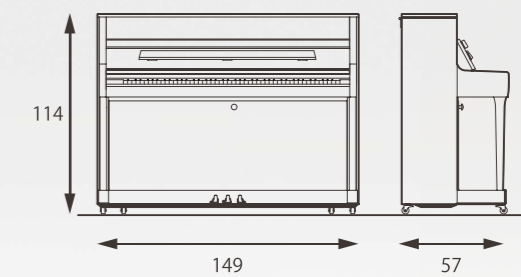

- Exclusive Millennium III Upright Action with ABS-Carbon Composites
- Double Felted, Mahogany Core Hammers





K-700



K-400

K-700 K-400

The K-700 and K-400 feature a grand-style music rack that places music at eye level and provides a solid surface for sheet music and oversized music books.

K-700

Height 130 cm Width 150 cm Depth 62 cm Weight 241 kg

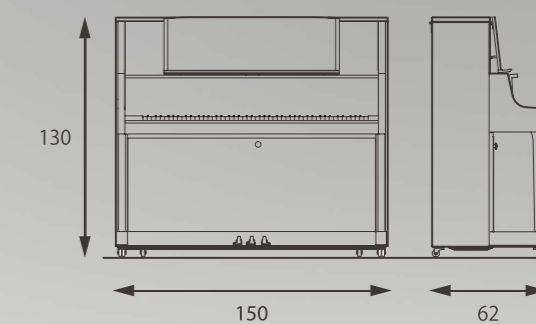

- Exclusive Millennium III Upright Action with ABS-Carbon Composites
- Duplex Scale (Fore)
- The duplex scale enhances harmonics in the treble range, adding brilliance and richness to the piano's tone.
- NEOTEX™ Key Surfaces
- Double Felted, Mahogany Core Hammers
- Grand-Style "Hard Finish" Music Rack

K-400

Height 122 cm Width 149 cm Depth 61 cm Weight 230 kg

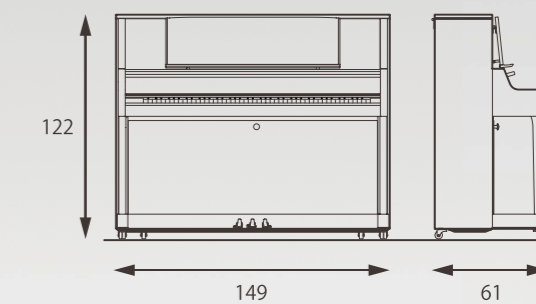

- Exclusive Millennium III Upright Action with ABS-Carbon Composites
- Double Felted, Mahogany Core Hammers
- Grand-Style Music Rack
- Dual-Hinged Fallboard

Availability of K-400 & K-700 may vary depending on market area. Please contact your local KAWAI dealer for details.



K-800



K-600

K-800 K-600

The K-800 and K-600's elegant form and exceptional tone will fulfill the needs of any professional teaching studio or intimate performance setting.

K-800

Height 134 cm Width 153 cm Depth 65 cm Weight 284 kg

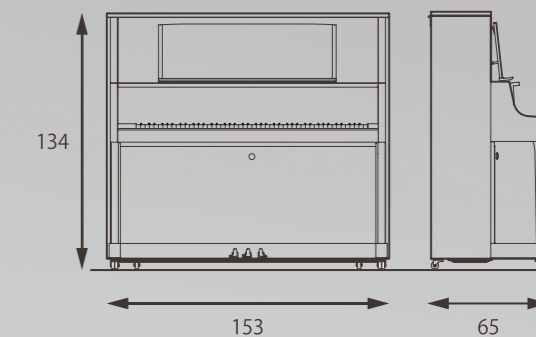

- Exclusive Millennium III Upright Action with ABS-Carbon Composites
- Agraffes
Agraffes ensure accuracy in string alignment, spacing and angles to produce greater uniformity, enhanced tone, smoother tuning and consistent "speaking length" for each note.
- Duplex Scale (Fore & Back)
- Grand-Style "Hard Finish" Music Rack
- NEOTEX™ Key Surfaces
- Double Felted, Mahogany Core Hammers



E/P

K-600

Height 134 cm Width 153 cm Depth 65 cm Weight 280 kg

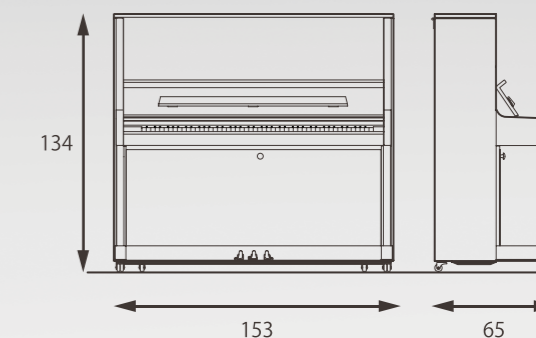

- Exclusive Millennium III Upright Action with ABS-Carbon Composites
- Agraffes
- Duplex Scale (Fore & Back)
- NEOTEX™ Key Surfaces
- Double Felted, Mahogany Core Hammers



E/P

AVAILABLE FINISHES



Sapele Mahogany Polish

For K-500



Mahogany Polish

For K-200 and K-300



Mahogany Satin

For K-200 and K-300



Dark Walnut Open Pore

For K-200



Ebony Satin

For K-200, K-300 and K-500



White Polish

For K-200 and K-300



SILVER HARDWARE

Availability of cabinet finishes may vary depending on market area. Please contact your local KAWAI dealer for details.

Availability of silver hardware models may vary depending on market area. Please contact your local KAWAI dealer for details.

HYBRID PIANO

ANYTIME X3

AnyTimeX3 instruments incorporate an acoustic muting feature with powerful digital audio components, allowing pianists to continue enjoying the distinctive feeling of a traditional piano more discreetly, without disturbing family members or neighbours.



Digital operation greatly extends the capabilities of the AnyTimeX3 piano beyond that of a traditional acoustic instrument, with convenient transpose and tuning facilities, a metronome and song recorder, and a selection of high fidelity sounds suitable for various musical occasions.

All AnyTimeX instruments utilise sensors integrated within the fine workings of the piano action to detect the precise movements of each hammer.



ATX3 Specifications		
Sound Source	Pianist mode	SK-EX Rendering: 88-key multi-channel piano sampling, 88-key resonance modelling
	Sound mode	Harmonic Imaging XL: 88-key piano sampling
Polyphony		max. 256 notes (depending on selected sound)
Internal Sounds	Pianist mode	SK-EX Concert Grand, 10 rendering characters
	Sound mode	88 sounds
Display		5" LCD touchscreen (480 x 800 pixels)
Effects	Pianist mode	Resonance Depth (10 types), Ambience (10 types)
	Sound mode	Reverb (6 types), Effects (24 types) (Chorus x 3, Delay x 3, Tremolo x 3, Auto pan x 2, Phaser x 2, Rotary x 6, Combination x 5)
USB Recorder	Playback	MP3, WAV, SMF, KSO (internal song file)
	Record	MP3, WAV, Save as SMF/KSO, Line In & Bluetooth Audio Recording
Bluetooth		Bluetooth (Ver. 4.1; GATT compatible)
		Bluetooth Low Energy MIDI Specification compliant, Bluetooth Audio
Internal Songs	Demo Songs	39 songs
	Piano Music	29 or 42 songs ¹
	Concert Magic	88 songs
	Lesson Books	Lesson Books 584 Songs from Alfred, Burgmüller, Czerny, Beyer, Bach and Chopin lesson books ² , 140 Finger Exercises
Virtual Technician	Pianist mode	Touch Curve (incl. User), Voicing (incl. User), Damper Noise, Fall-back Noise, Hammer Delay, Minimum Touch, Key Volume (incl. User), Half-Pedal Adjust, Soft Pedal Depth
	Sound mode	Touch Curve (incl. User), Voicing (incl. User), Damper Resonance, Damper Noise, String Resonance, Undamped String Resonance, Cabinet Resonance, Key-off Effect, Fall-back Noise, Hammer Delay, Topboard Simulation, Decay Time, Minimum Touch, Stretch Tuning (incl. User), Temperament (incl. User), Temperament Key, Key Volume (incl. User), Half-Pedal Adjust, Soft Pedal Depth

¹ Depending on market location.

² Lesson books sold separately.

* Availability of Bluetooth function dependent on market location. Specifications are subject to change without notice.

SPECIFICATIONS



Model	K-200	K-300	K-400	K-500	K-600	K-700	K-800										
Size	Height (cm)	114	122	122	130	134	134										
	Width (cm)	149	149	149	150	153	153										
	Depth (cm)	57	61	61	62	65	65										
	Weight (kg)	208	227	230	238	280	284										
Soundboard	Materials	Solid Spruce, Tapered															
	Area (m2)	1.34	1.39	1.39	1.45	1.52	1.52										
Back Posts	4	5	5	5	6	5	6										
Cutoff Bar	1	2	2	2	2	2	2										
Action	Millennium III																
Hammers	Felting	All Underfelted															
	Materials	Mahogany															
Key Surfaces	Acrylic/Phenol	Acrylic/Phenol	Acrylic/Phenol	NEOTEX	NEOTEX	NEOTEX	NEOTEX										
Speaking length of #1 string (mm)	1,157	1,200	1,200	1,230	1,280	1,230	1,280										
Tuning Pins	Nickel-plated																
Duplex Scale	-	-	-	Fore	Fore & Back	Fore	Fore & Back										
Agraffes	-	-	-	-	1 - 51 key	-	1 - 51 key										
Front Casters	Single, Brass	Double, Brass	Double, Brass	Double, Brass	Double, Brass	Double, Brass	Double, Brass										
Music Rack	Hard Finish	-	-	-	-	○	○										
	Width of Music Rack (cm)	100	100	94	100	94	105										
Lock	-	-	-	○	○	○	○										
Available finishes	 Availability of cabinet finishes may vary depending on market area. Please contact your local KAWAI dealer for details.																
	E/P	E/S	MH/P	MH/S	WH/P	DW/OP	E/P	E/S	MH/P	MH/S	WH/P	E/P	E/S	SM/P	E/P	E/P	E/P

CARING FOR OUR WORLD

In 1997, Kawai's Ryuyo Grand Piano Factory became the first in the piano industry to receive ISO14001, the world's most prestigious certification for excellence in environmental management. At Ryuyo, work groups continuously monitor and improve emissions and waste control, green procurement, and a host of other energy conservation and environmental protection measures. The Kawai Forest Project has already planted over 400,000 seedlings. These vital efforts will continue to be a part of every piano we build. That is our promise to you—and to our world.



A FAMILY TRADITION

There is no more compelling reason to build an exceptional piano than one's own name on the instrument.

For generations, the Kawai family has blended knowledge, skill, technology, and heart...in the quest to perfect the art of the piano.

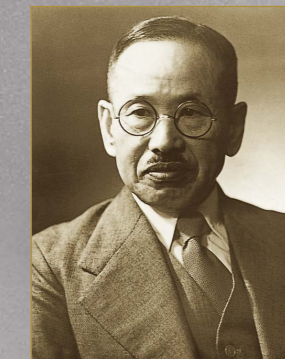

KOICHI KAWAI
FOUNDER
(1886-1955)

INVENTIVE GENIUS,
MASTER BUILDER



SHIGERU KAWAI
(1922-2006)

PURSUED EXCELLENCE
AT KAWAI FOR OVER
FIFTY YEARS.

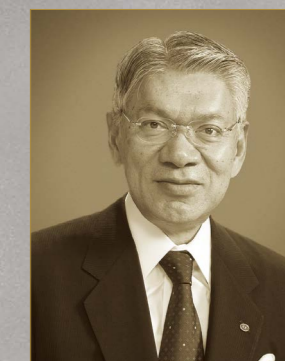

HIROTAKA KAWAI
PRESIDENT

CONTINUING THE PURSUIT
OF PERFECTION.

KAWAI
THE FUTURE OF THE PIANO

<http://www.kawai-global.com>